

P8-TYPE

CLASS

Classification	DNV GL X100 A5 Strengthened for heavy cargoes	
Ice-Class	E3	
Fitted for carriage of dangerous goods of all IMO classes		
Fitted for trading Australia		

PRINCIPAL DIMENSIONS

Length over all	168.68 m	
Breadth extreme	25.43 m	
Height Hold 1	14.20 m	
Height Hold 2	14.90 m	
Summer draft	9.50 m	
GT	Abt. 17,634	
NT	Abt. 6,617	
DEADWEIGHT Summer	20,100 mt	excl. TWD

CAPACITY

Grain - bale	929,696	cbft / 26,337m ³
--------------	---------	-----------------------------

FLOOR SPACE

Tank top	Hold 1: 281 m ²	
	Hold 2: 1.332 m ²	
Tween deck	Hold 1: 281 m ²	
	Hold 2: 1,458 m ²	
Weather deck	2,220 m ²	

AIR CHANGES (basis empty holds)

Abt. 6 x p/h

CONTAINER INTAKE

Total	912 TEU	Intake always subject stability
-------	---------	---------------------------------

HATCHES

Weather deck	No.1: 22.94 x 14.26 m	
	No.2: 82.40 x 19.16 m	
	hydraulic folding type, combinable w/pontoons	
Tween deck	No.1: 22.94 x 13.76 m	
	No.2: 82.40 x 18.66 m	
	Heights: Tween deck	Hold 1 2 different heights Hold 2 4 different heights

MAXIMUM LOAD

Weather deck hatch covers	5.00 t/m ²
Tweendeck hatch covers	3.50 t/m ²
Tank top	18.00 t/m ²

DECK CRANES

Position	2 x 400 mt SWL situated on port side Combinable 800 mt SWL 180 mt SWL situated on starboard side Parkgracht: 120 mt SWL situated on starboard side
Tons/reach	2 x 400 mt SWL / 18 m 2 x 325 mt SWL / 22 m 2 x 240 mt SWL / 30 m 1 x 180 mt SWL / 13 m Parkgracht: 1 x 120 mt SWL / 16 m
BOWTHRUSTER	1 x 800 kW



- 2009 PARKGRACHT
- 2011 PRINSENGRACHT
- 2012 PIETERSGRACHT

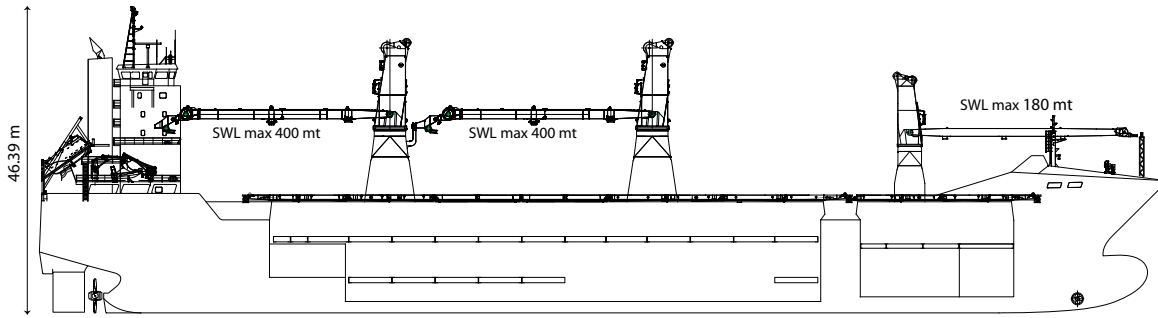

WEATHER DECK

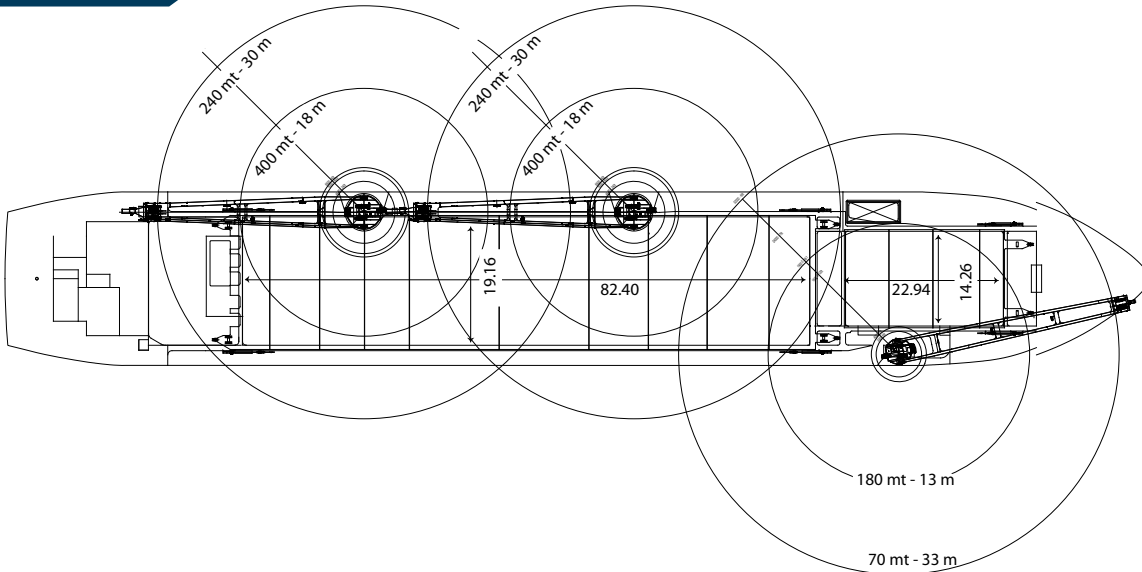

TWEEN DECK

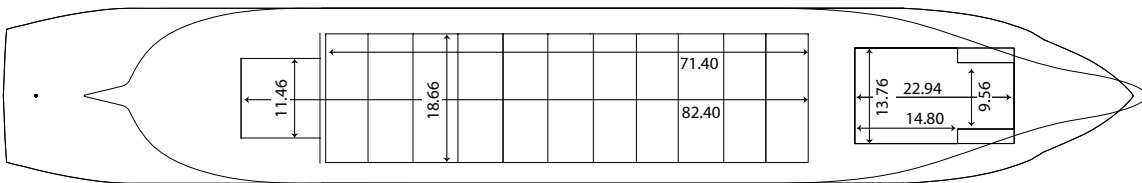

TANK TOP

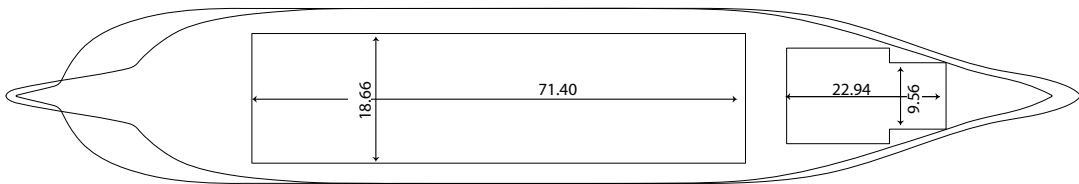

CROSS SECTION

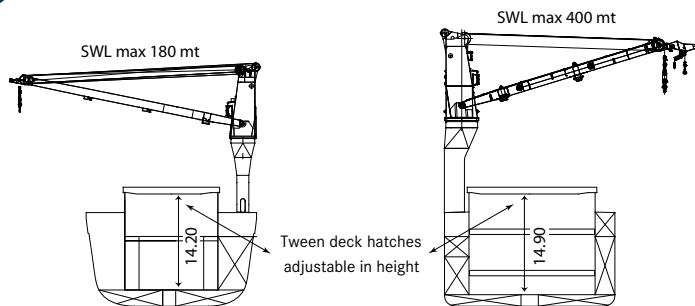

These particulars are believed to be correct, but without guarantee, and they must not be used as basis for Charter Parties or contracts without explicit written authority. For more information please contact amsterdam@spliethoff.com

P8-TYPE