

# F-TYPE

CLASS		
Classification	Bureau Veritas ✱ 100 A1	
Ice-Class	Ice class 1A (Finnish)	
Open sailing notation	No	
Fitted for carriage of dangerous goods of all IMO classes		
Fitted for trading Australia and Great Lakes		
PRINCIPAL DIMENSIONS		
Length over all	136,64 m	
Breadth moulded	18,90 m	
Height hold as SID	11,75 m	
Height lower hold as TWD	3,19 or 6,35 or 8,85 m *	* except where side tanks in hold 1+3 where lowest position not available
Height tween deck as TWD	7,85 or 4,70 or 2,20 m *	
Summer draft	8,52 m	
GT	Abt. 8.620	
NT	Abt. 4.398	
DEADWEIGHT all told	Abt. 12.500 mt	excl. TWD
	Abt. 12.075 mt	incl. TWD
CAPACITY		
Grain - bale	556.980 cbft	/15.772 m <sup>3</sup>
FLOOR SPACE		
Tank top	1.270 m <sup>2</sup>	
Tween deck	1.419 m <sup>2</sup>	
Weather deck	1.589 m <sup>2</sup>	
AIR CHANGES (basis empty holds)		
Hold 1	Abt. 30 x p/h	
Dehumidifier	Yes	
CONTAINER INTAKE		
Total	658 TEU	Intake always subject stability
HATCHES		
Weather deck	No.1: 26,60 x 15,80 m	
	No.2: 31,74 x 15,80 m	
	No.3: 26,60 x 15,80 m	
	Steel, end folding type	
Tween deck	No.1: 28,00 x 15,80 m	
	No. 2: 61,84 x 15,80 m	
	17 steel pontoons	
Bulkheads/compartments: Removable pontoons for up to 11 compartments at TEU interval		
MAXIMUM LOAD		
Weather deck hatch covers	2,00 t/m <sup>2</sup>	
Tweendeck hatch covers	4,50 t/m <sup>2</sup>	
Tank top	20,00 t/m <sup>2</sup>	
DECK CRANES		
Position	3 x situated on starboard side	
Tons /reach	80 mt SWL/18 m	
	65 mt SWL/24 m	



- 2010** FLORIJNGRACHT
- 2011** FAGELGRACHT  
FLEVOGRACHT  
FLORAGRACHT
- 2012** FORTUNAGRACHT\*  
FLORETGRACHT\*

\* different hold 1 configuration

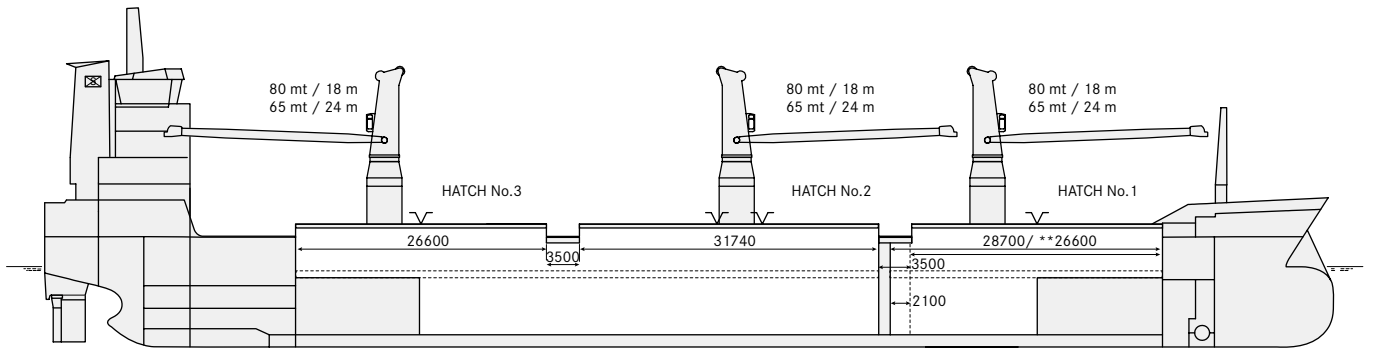

### WEATHER DECK

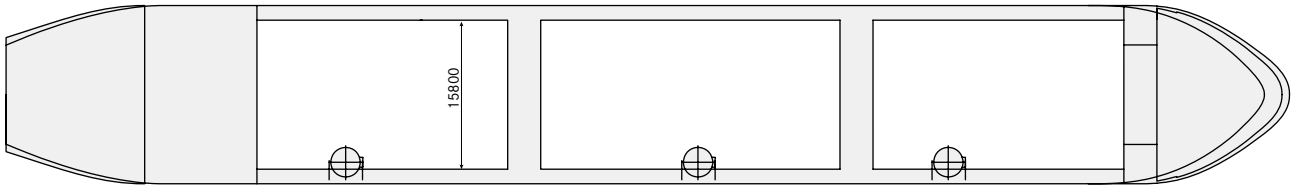

### TWEEN DECK

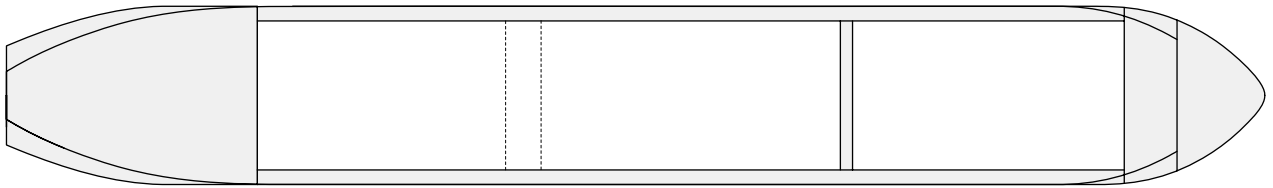

### TANK TOP

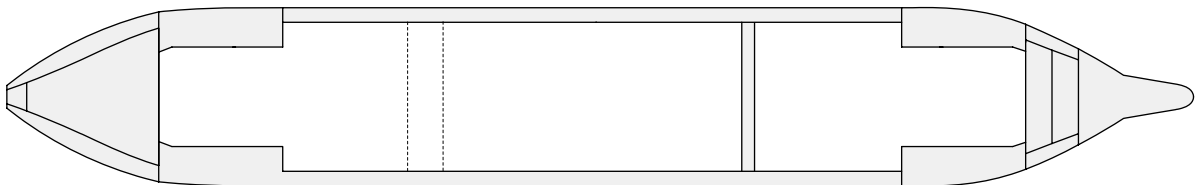

### CROSS SECTION

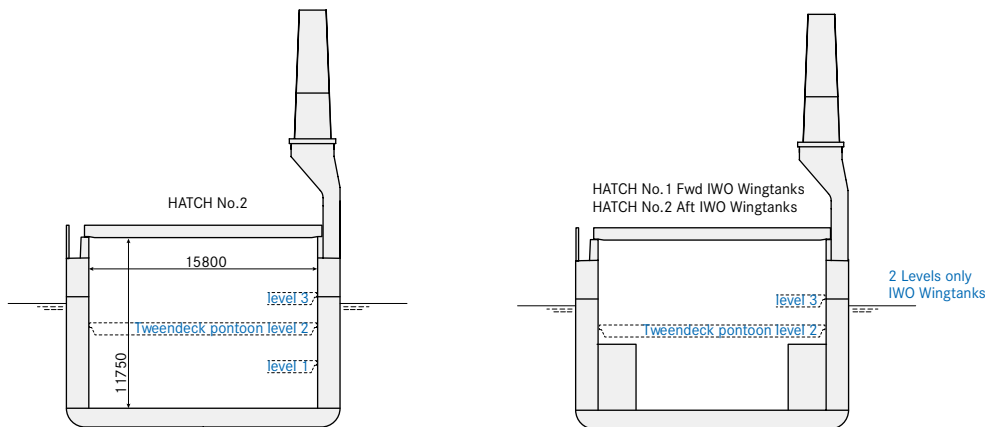

These particulars are believed to be correct, but without guarantee, and they must not be used as basis for Charter Parties or contracts without explicit written authority. For more information please contact [amsterdam@spliethoff.com](mailto:amsterdam@spliethoff.com)

# F-TYPE