

S-TYPE

CLASS		
Classification	Lloyd's Register ✱100 A1	
Ice-Class	Finnish/ Swedish 1A	
Fitted for carriage of dangerous goods of all IMO classes		
Fitted for trading Australia		
Open sailing notation	No	
PRINCIPAL DIMENSIONS		
Length over all	168,21 m	/ 173,18 m*
Breadth moulded	25,20 m	/ 25,30 m*
Height hold as SID	14,38 m	Hold 1: 11,88 m
Height lower hold as TWD	3,18 or 7,03 or 10,23 m	Hold 1: 4,63 m
Height tween deck as TWD	3,05 or 6,25 or 10,10 m	Hold 1: 6,25 m
Summer draft	10,74 m	
GT	Abt. 16.641	
NT	6.730	
DEADWEIGHT all told	21.400 mt	excl. TWD
	20.760 mt	incl. TWD
CAPACITY		
Grain - bale	840.250 cbft	/ 23.820 m ³
FLOOR SPACE		
Tank top	1.620 m ²	
Tween deck	1.834 m ²	
Weather deck	2.155 m ²	
AIR CHANGES (basis empty holds)		
Hold 0,1,2,3	Abt. 6 x, 20 x, 20 x p/h	
Dehumidifier	Yes	
CONTAINER INTAKE		
Total	1.134 TEU	Intake always subject stability
HATCHES		
Weather deck	No.0: 6,40 x 7,60 m	
	No.1: 25,60 x 17,80 m / 15,20 m	
	No.2: 38,40 x 17,80 m	
	No.3: 32,00 x 20,40 m	
	Steel, end folding/rolling/lift away type	
Tween deck	No.1: 25,60 x 17,80 m	
	No.2: 38,40 x 17,80 m / 4,40 x 17,80 m (under cross beam)	
	No.3: 32,00 x 20,40 m	
	16 steel pontoons	
Bulkheads/compartments: Removable pontoons for up to 14 compartments at TEU interval		
MAXIMUM LOAD		
Weather deck hatch covers	2,00 t/m ²	payload
Tweendeck hatch covers	Hatchway 1: 7,50 t/m ²	
	Hatchway 2: 5,50 t/m ²	
	Hatchway 3: 5,00 t/m ²	
Tank top	20,00 t/m ²	
DECK CRANES		
Position	2 x port side (aft and mid), 1 x starboard (forward)	
Tons /reach	120 mt SWL/ 14 m	
	90 mt SWL/ 18,6 m	
	55 mt SWL/ 30 m	
SIDELOADERS		
Position	5 x starboard side	
Capacity	16 mt SWL	



- 2000** SCHIPPERSGRACHT
SINGELGRACHT
SLOTGRACHT,
SNOEKGRACHT
SPAARNEGRACHT
SPIEGELGRACHT,
SCHELDEGRACHT*,
STADIONGRACHT*
- 2001** 2001 SLUISGRACHT*,
SPIUGRACHT*
- 2004** STATENGRACHT*

* different in length and breadth

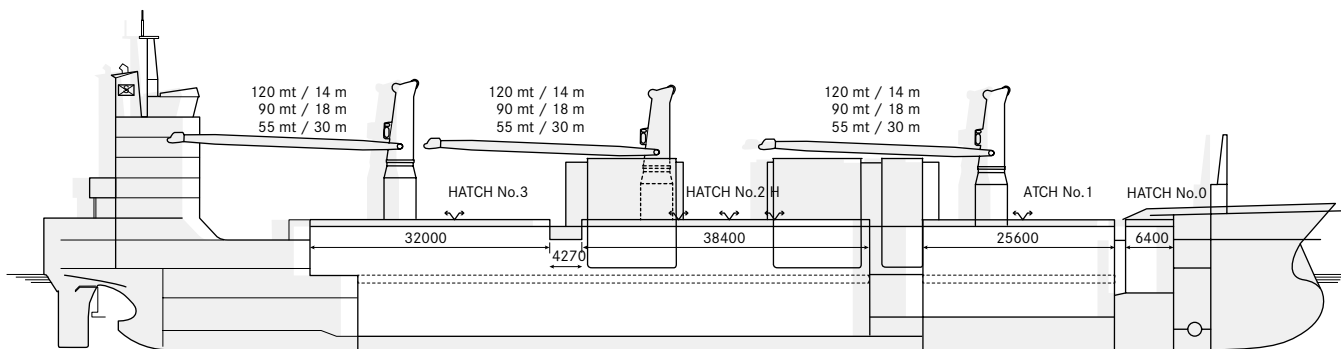

WEATHER DECK

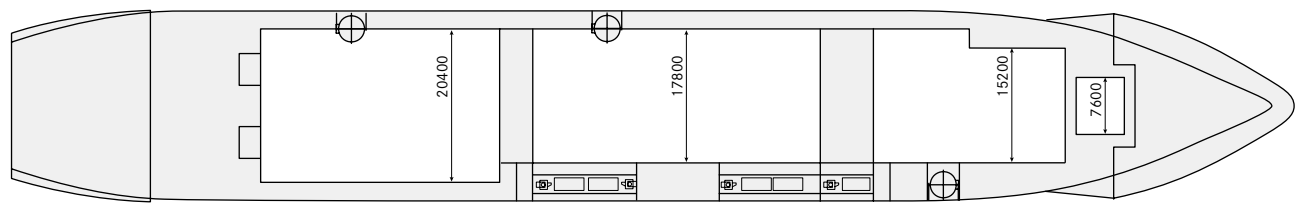

TWEEN DECK

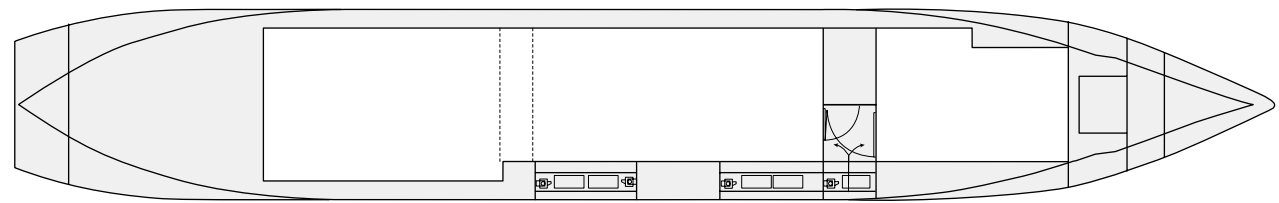

TANK TOP

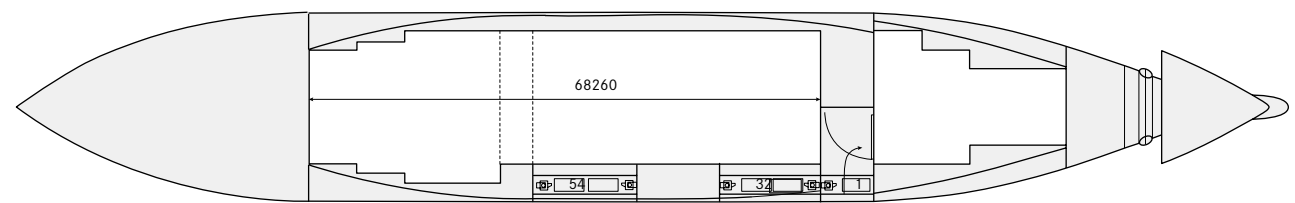

CROSS SECTION

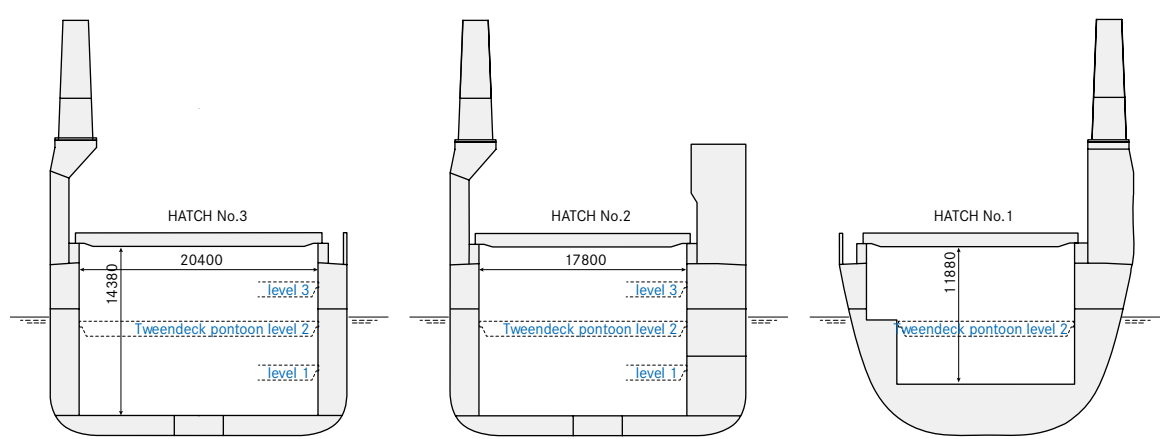

These particulars are believed to be correct, but without guarantee, and they must not be used as basis for Charter Parties or contracts without explicit written authority. For more information please contact amsterdam@spliothoff.com

S-TYPE